

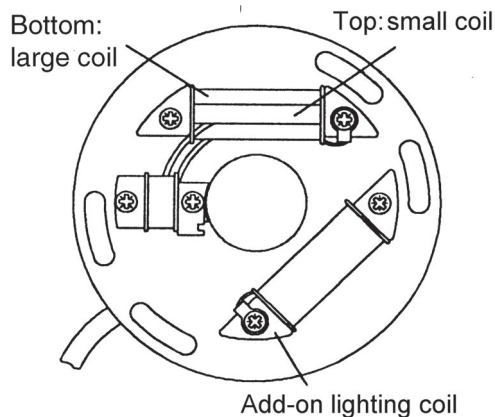

Installation instructions for IGNITION COIL:
KAWASAKI KD400 1984-85, KDX500 1984-85
YAMAHA YZ465, YZ490

- ❖ Take the ignition cover off.
- ❖ Take note of the wire colors of the original stator wires and disconnect them from the wiring loom.
- ❖ Remove the flywheel using a proper puller tool.
- ❖ Remove the baseplate with the original stator.
- ❖ Remove the screws that secure the ignition coils and take the coils off.
- ❖ Cut the original wires close to the ignition coils. Take a good look at how the wires are connected to the coils.
- ❖ Connect the old wires up to the new coils. Put the wires in the same place as on the original.
- ❖ **CONNECTIONS:** One side of the top small coil needs to be grounded. Connect the RED wire to the other side of the small coil. One side of the bottom large coil needs to be grounded. Connect the BLACK/RED wire to the other side of the large coil. Connect the wires to the same side of the coils compared to the original setup.



- ❖ Mount the coils onto the baseplate. Stack the two coils on top of each other. The small coil needs to be fitted at the top. Fit the screws using locking compound on the threads and **TIGHTEN THE SCREWS SECURELY!**
- ❖ Refit the stator baseplate. Ensure that the flywheel **CANNOT TOUCH THE WIRES!** (especially on the inside of the flywheel)
- ❖ Refit the flywheel. Tighten the bolt to specified torque.
- ❖ Connect the wires to the wiring loom on the bike, and fit the ignition cover.
- ❖ If you experience any problems, contact us at:

Ricky Stator

1672 Main St., Unit E, PMB 104, Ramona, CA 92065
760-787-0094 • Fax 787-0313 • E-mail: stator@adnc.com • www.rickystator.com



Installation instructions for IGNITION COIL:
KAWASAKI KD400 1984-85, KDX500 1984-85
YAMAHA YZ465, YZ490

- ❖ Take the ignition cover off.
- ❖ Take note of the wire colors of the original stator wires and disconnect them from the wiring loom.
- ❖ Remove the flywheel using a proper puller tool.
- ❖ Remove the baseplate with the original stator.
- ❖ Remove the screws that secure the ignition coils and take the coils off.
- ❖ Cut the original wires close to the ignition coils. Take a good look at how the wires are connected to the coils.
- ❖ Connect the old wires up to the new coils. Put the wires in the same place as on the original.
- ❖ **CONNECTIONS:** One side of the top small coil needs to be grounded. Connect the RED wire to the other side of the small coil. One side of the bottom large coil needs to be grounded. Connect the BLACK/RED wire to the other side of the large coil. Connect the wires to the same side of the coils compared to the original setup.

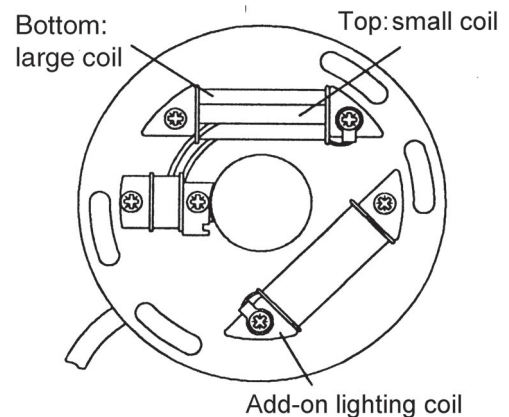

- ❖ Mount the coils onto the baseplate. Stack the two coils on top of each other. The small coil needs to be fitted at the top. Fit the screws using locking compound on the threads and **TIGHTEN THE SCREWS SECURELY!**
- ❖ Refit the stator baseplate. Ensure that the flywheel **CANNOT TOUCH THE WIRES!** (especially on the inside of the flywheel)
- ❖ Refit the flywheel. Tighten the bolt to specified torque.
- ❖ Connect the wires to the wiring loom on the bike, and fit the ignition cover.
- ❖ If you experience any problems, contact us at:

Ricky Stator

1672 Main St., Unit E, PMB 104, Ramona, CA 92065
760-787-0094 • Fax 787-0313 • E-mail: stator@adnc.com • www.rickystator.com