

XR 400R Stator Instructions



The RS XR400R stator is a 200 watt stator that can be configured two different ways: A dual output of 100 watts each or a single output of 200 watts. When using the stator as a stock replacement where no additional output is required or with **most dual sport kits** a dual output configuration will be the preferred method of operation. If the stator is going to be used for additional lighting with no battery in the system a single output configuration is the preferred method, a heavy duty AC regulator is highly recommended in place of the stock AC regulator.

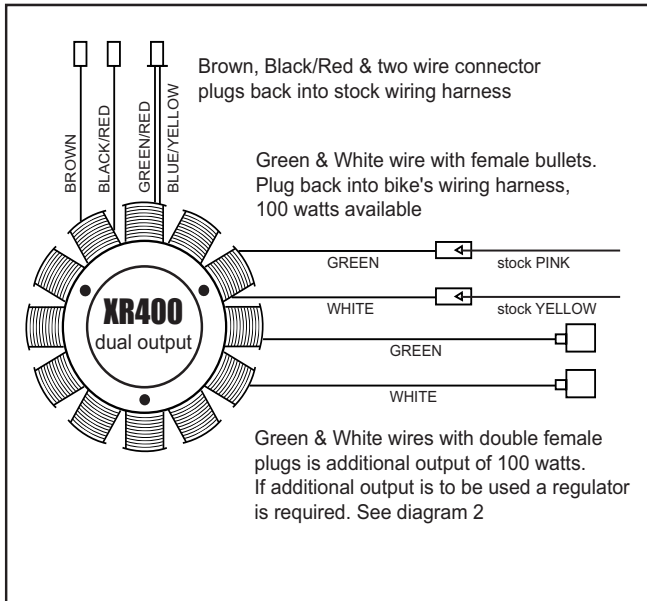

Diagram 1

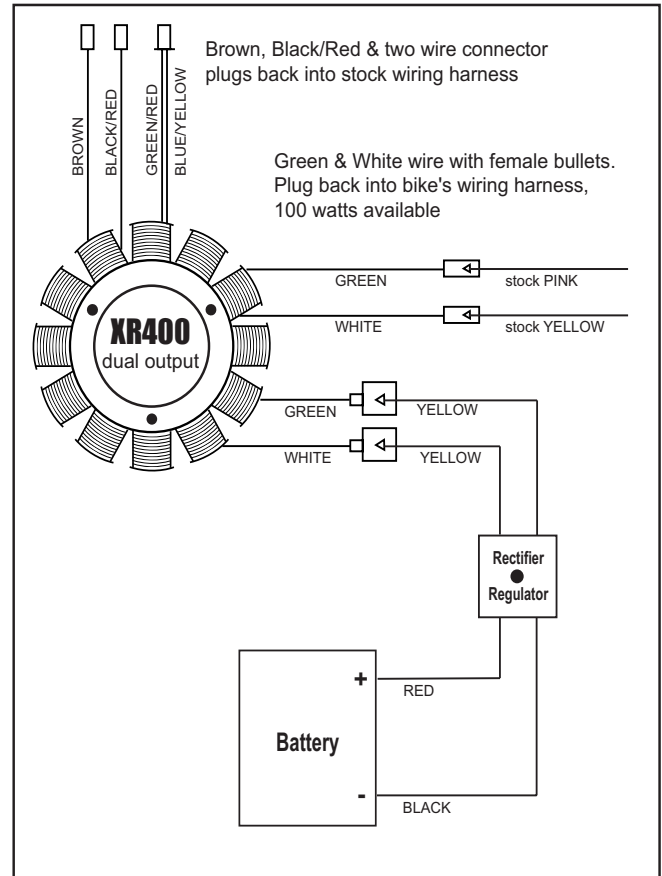

Diagram 3

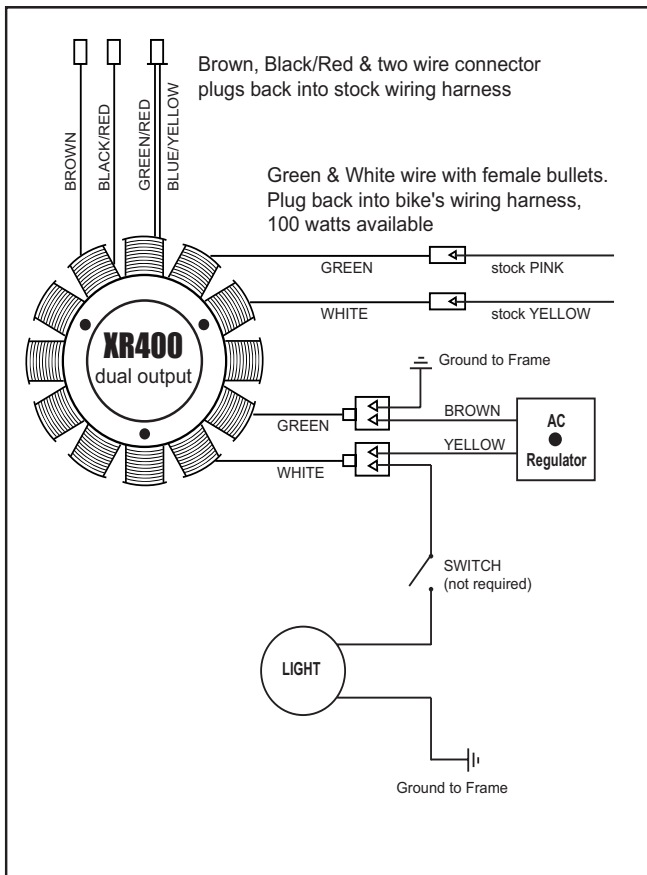

Diagram 2

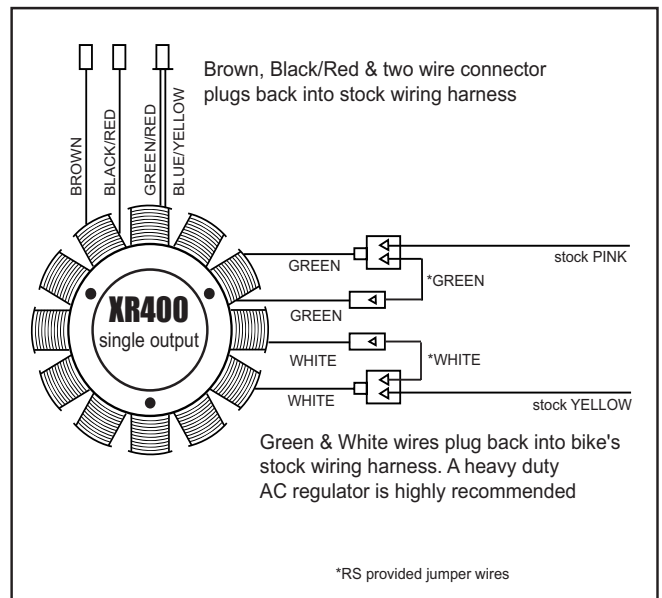

Diagram 4: Single output of 200 watts